

TM-2-A7-PC0 Torque Motor

Electrical specifications

Winding code : PC0	Symbol	Unit	Water cooling
Continuous torque	T_c	Nm	633
Continuous current	I_c	A_{rms}	35
Stall torque	T_s	Nm	518
Stall current	I_s	A_{rms}	28
Peak torque(for 1sec.)	T_p	Nm	1200
Peak current(for 1sec.)	I_p	A_{rms}	78
Torque constant	K_t	Nm/Arms	19.4
Electrical time constant	T_e	ms	6.8
Resistance (line to line at 25°C)	R_{25}	Ω	1.6
Inductance (line to line)	L	mH	10.8
Number of poles	2p		66
Back emf constant (line to line)	K_v	Vrms/rad/s	11.2
Motor constant (at 25°C)	K_m	Nm/ \sqrt{W}	12.53
Thermal resistance	R_{th}	K/W	0.036
Thermal sensor			PTC SNM100+SNM130+Pt1000
Max. DC BUS		V_{DC}	750
Inertia of rotor	J	kgm^2	0.151
Thermal time constant	T_{th}	s	130
Max. continuous power dissipation	P_c	W	4152
Max. peak power dissipation	P_p	W	20624
Rated speed(at 600VDC)		rpm	216

Mechanical specifications

	Symbol	Unit	Water cooling
Mass of rotor	M_r	kg	7.6
Mass of stator	M_s	kg	34.5
Height of stator	H_s	mm	130
Height of rotor	H_r	mm	71
Length of rotor centring fit	H	mm	15
Water temperature difference for P_c	$\Delta\theta$	K	5
Minimum water flow	q	l/min	11.9
Max. pressure drop	Δp	bar	1

T-N curve

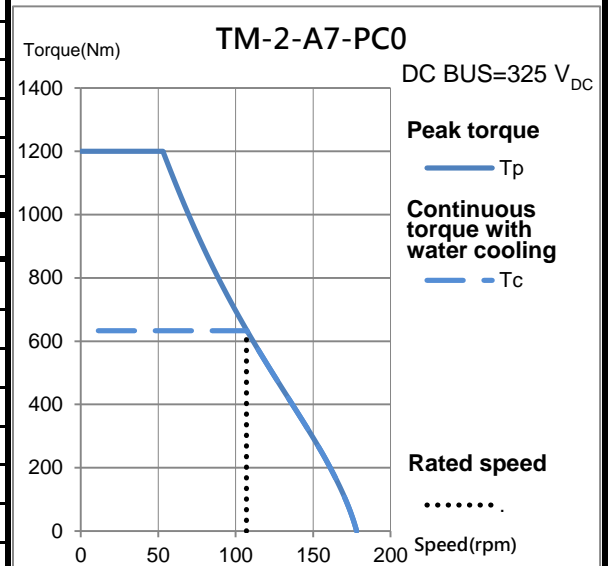
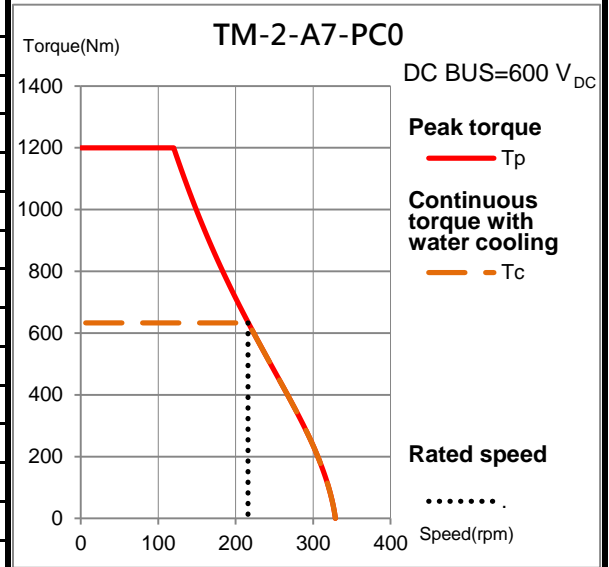

Thermal sensor

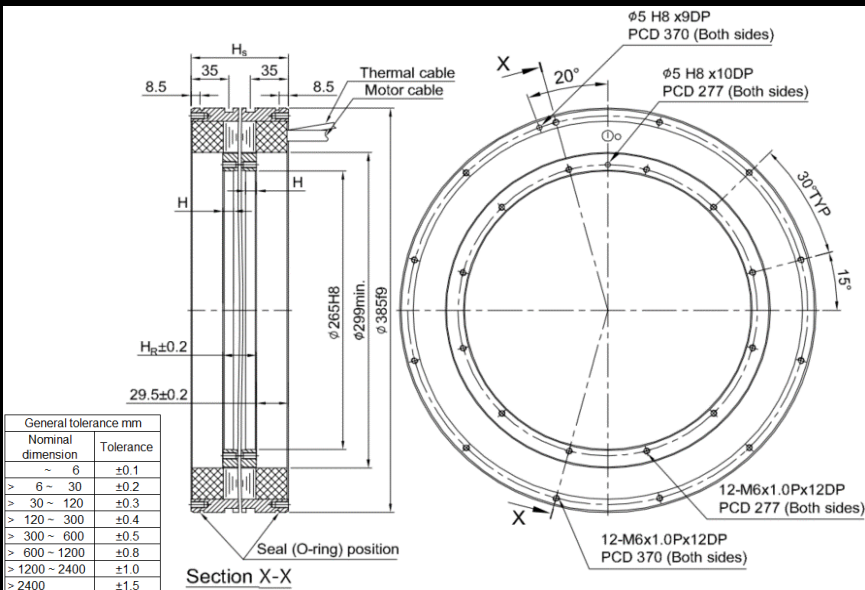
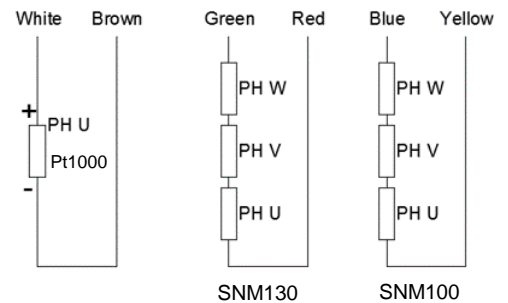

General tolerance mm	
Nominal dimension	Tolerance
> 6	±0.1
> 6 - 30	±0.2
> 30 - 120	±0.3
> 120 - 300	±0.4
> 300 - 600	±0.5
> 600 - 1200	±0.6
> 1200 - 2400	±1.0
> 2400	±1.5

Motor wire table	
Color or wire no.	Signal
U/L1	PH U
V/L2	PH V
W/L3	PH W
Green/Yellow	GND

Except dimensions, all the specifications in the table are in ±10% of tolerance

Version: 2.00

This drawing is only for reference, detail dimensions please refer to approval drawing.

Date: 2020/10/23